



Servo Press Straight Tool **NEW**



Tool Configuration

Model	Max Rated Load (kN)	Max Continuous Load (kN)	Maximum Speed (mm/sec)	Standard Stroke (mm)	Total Length (mm)	Applicable Controller
DPR-101R3-30FB	10	2.5	238	300	1005	MFC-S060S
DPR-301R4J-30FB-CE	30	8.3	200	300	1039	MFC-S120S
DPR-501R4J-30FB-CE	50	10.4	160	300	1148	MFC-S120S

*Software version upgrade is required to replace the conventional product.

Controller Ver.	V1.432	UserConsole Ver.	V1.301
-----------------	--------	------------------	--------



System Configuration

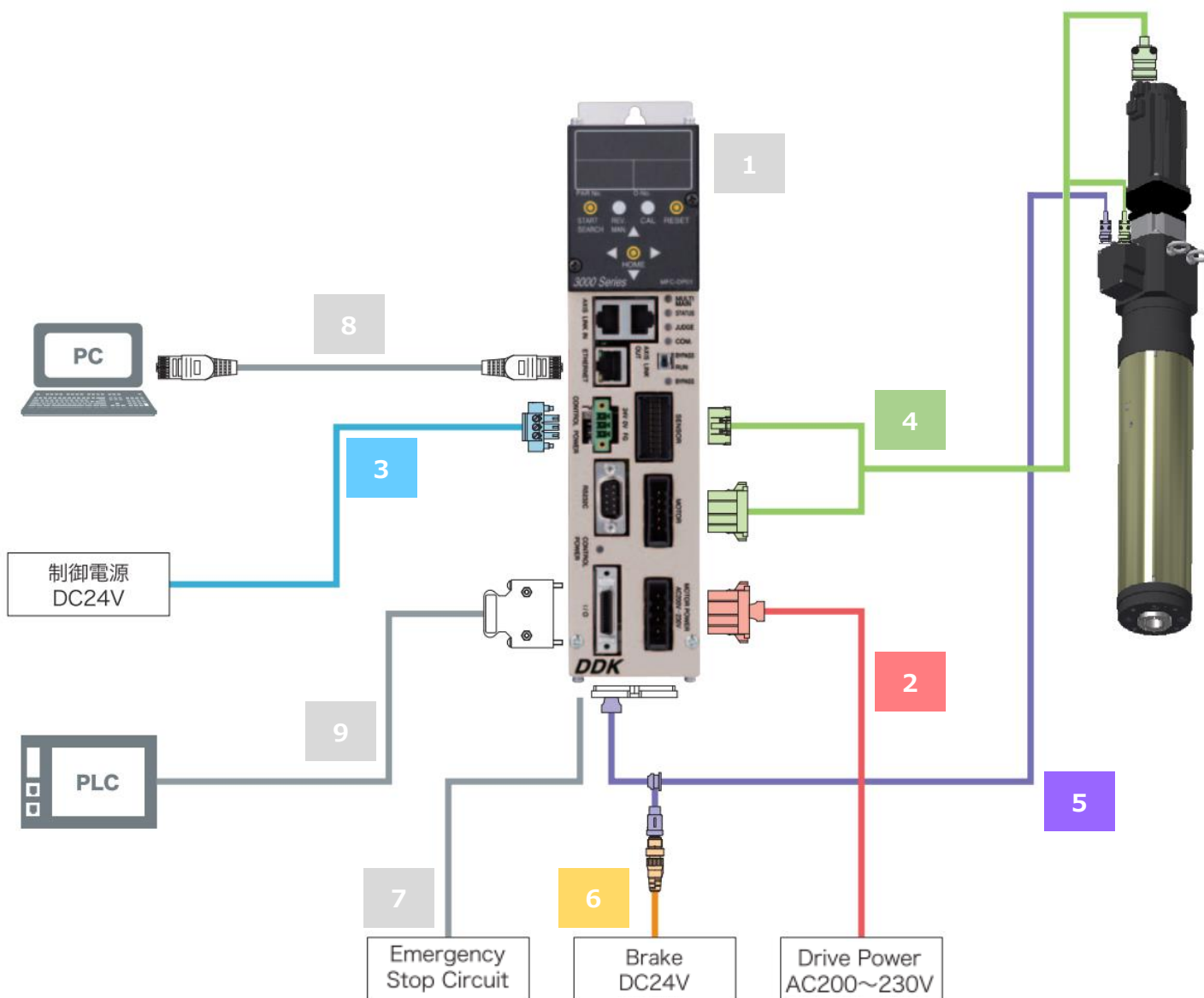

No	Name	Model	No	Name	Model
1	Controller	MFC-S120S	6	Brake Cable	C15-B3-M1-U
2	Drive Power Cable	C15-D2-M**	7	Stop Signal Cable	C30-XA1-M**
3	Control Power Cable	C30-DC1-M**	7	Stop Signal Connector	MC1.5/2-STF-3.81
3	Control Power Connector	MC1.5/3-STF-3.81	8	Ethernet Crossover	C30-UL1-M**
4	Tool Cable	C30-FW4-M	9	Standard I/O Cable	C30-SU1-M**
5	Limit Sensor & Brake Cable	C30-L3-M**	9	Standard I/O Connector	10126-3000PE

※For details, please contact us.

Specification and outline might be changed without notice due to system improvement.